

Miniwhizzy

Automatic dispensers for coupons and gadgets



Per coupon e gadget

It is the smallest feeder available, with direct current motor, with a speed up to 70 meters/minute to process products up to 150 mm width.

Etipack reserves the right to modify according to the technical evolution, without notice. All the rights of intellectual and technological ownership are reserved

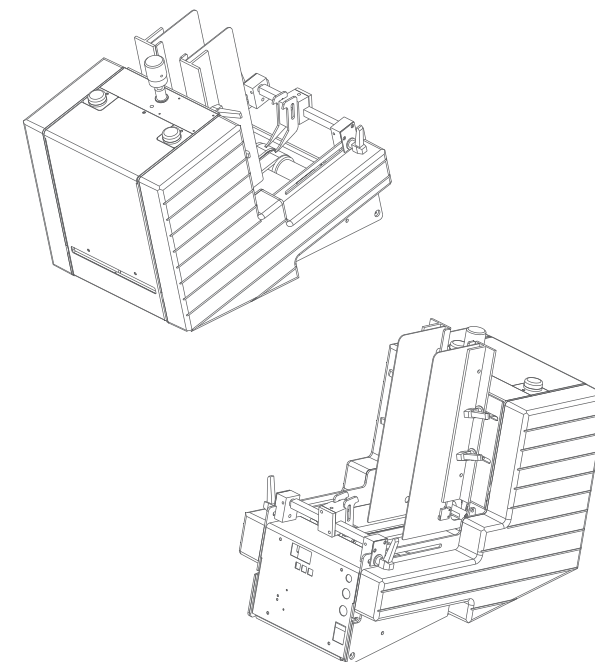
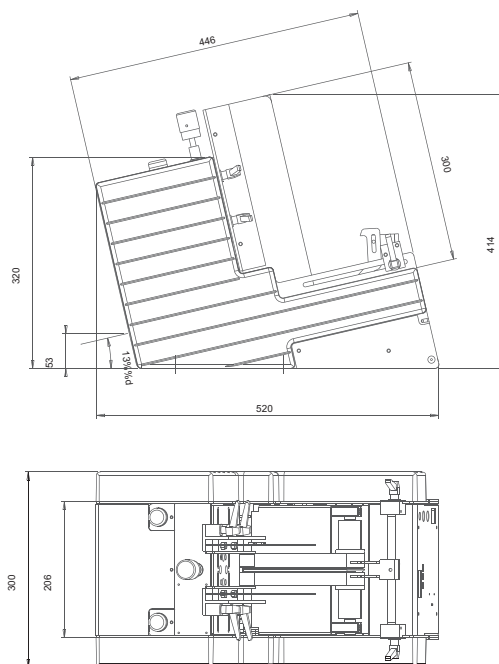

TECHNICAL SPECIFICATIONS

Miniwhizzy

Dispensing speed	70 mt / min
Product size length	50 - 180 mm
Product size width	50 - 150 mm
Product thickness	0,2 - 10 mm
Product dispensing	—
Motor	direct current
Machine size length - width - h	520 x 300 x 420 mm
Electrical board size length - width - h	—
Power supply	230 V, 50-60 Hz
Electrical input	100 W

Whizzy

Automatic dispensers for coupons and gadgets



For coupons and gadgets

Accurate and versatile, it adapts to the different kinds of packaging lines: with horizontal or vertical dispensing module, available in the Whizzy 210 version for products up to 210 mm width or in the Whizzy 350 version for products up to 350 mm width, with direct current (speed up to 40 mt/min.) or brushless motor (speed up to 200 mt/min.).

Etipack reserves the right to modify according to the technical evolution, without notice. All the rights of intellectual and technological ownership are reserved

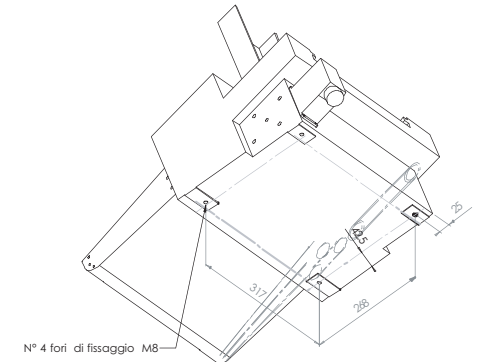
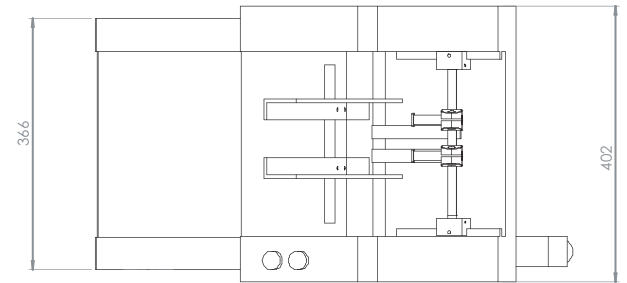
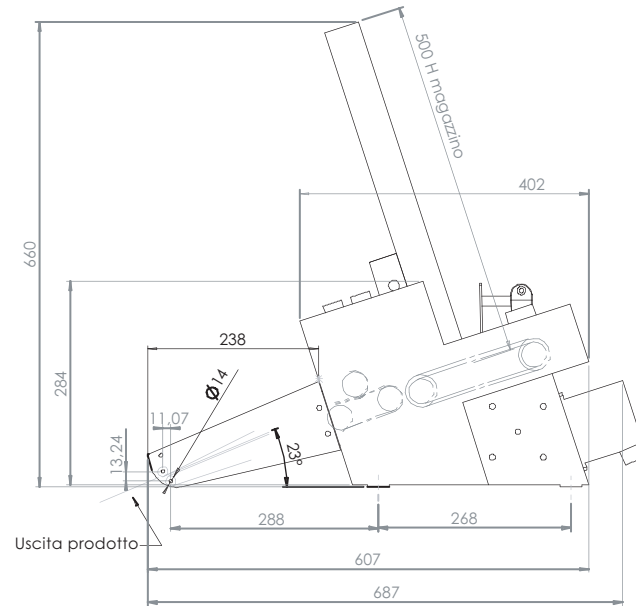

TECHNICAL SPECIFICATIONS

	Whizzy 210 BRO/BRV	Whizzy 350 BRO/BRV
Dispensing speed	200 mt/min	100 mt/min
Product size length	55 - 180 mm	100 - 180 mm
Product size width	50 - 210 mm	100 - 350 mm
Product thickness	0,2 - 4 mm	0,2 - 4 mm
Product dispensing	horizontal *	horizontal *
Motor	brushless	stepper motor
Machine size length - width - h	687 x 402 x 682 mm *	687 x 552 x 682 mm *
Electrical board size length - width - h	500 x 255 x 700 mm	550 x 255 x 700 mm
Power supply	230 V, 50-60 Hz	230 V, 50-60 Hz
Electrical input	700 W	700 W

* Whizzy 210 BRV
vertical dispensing
530 x 402 x 902 mm

* Whizzy 350 BRV
vertical dispensing
530 x 402 x 902 mm



Whizzy CB

Automatic dispensers for coupons and gadgets



For coupons and gadgets

This friction feeder picks sheets from the top of a stacker that can be loaded up to 150 mm high. This device makes it possible to distribute large sheets, such as instruction leaflets, posters and brochures: "Whizzy Bottom Loader" is available in two versions, for A4 and A3 sheets.

Etipack reserves the right to modify according to the technical evolution, without notice. All the rights of intellectual and technological ownership are reserved

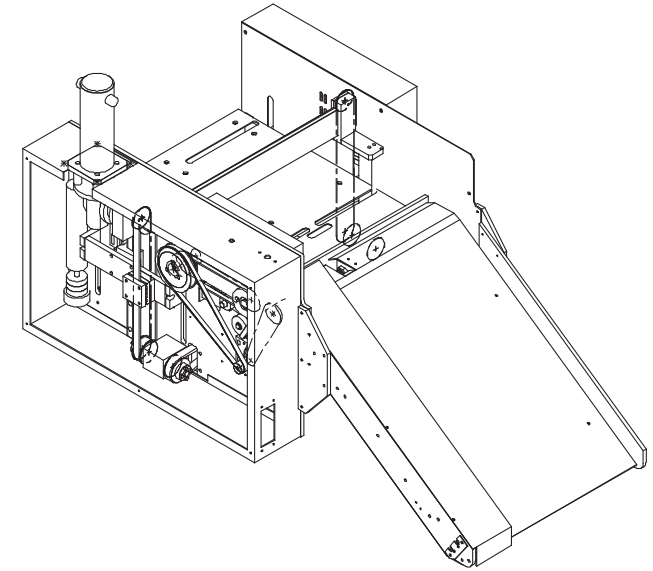
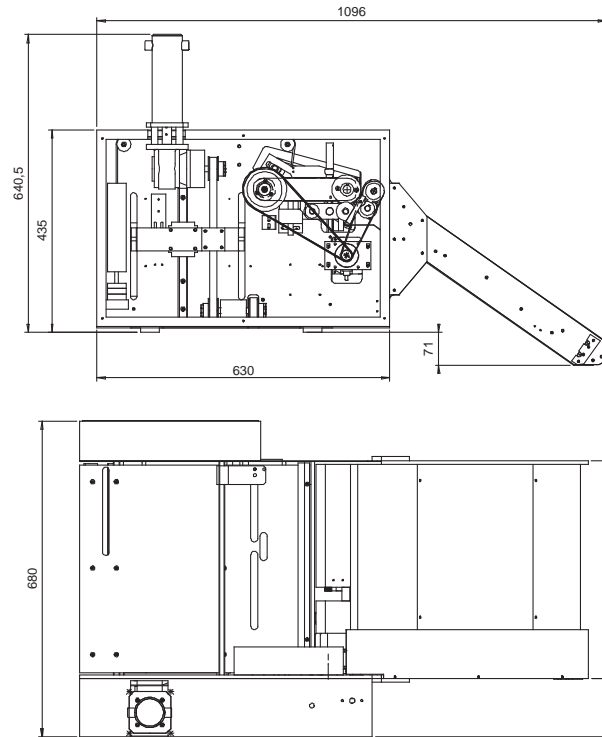

TECHNICAL SPECIFICATIONS

Dispensing speed	100 mt/min
Product size length	150 - 295 mm
Product size width	100 - 210 mm
Product thickness	0,5 - 4 mm
Product dispensing	horizontal
Motor	brushless
Machine size length - width - h	1100 x 480 x 640 mm
Electrical board size length - width - h	500 x 255 x 700 mm
Power supply	230 V, 50-60 Hz
Electrical input	700 W

Whizzy CB

Whizzy Roll

Automatic dispensers for coupons and gadgets



For bags in strips

Bandolier feeder to cut and dispense bags with 3 or 4 seams. The material can be supplied on a reel or fanfolded. After reading a notch, the machine receives a stop signal and starts cutting and dispensing the product.

Etipack reserves the right to modify according to the technical evolution, without notice. All the rights of intellectual and technological ownership are reserved

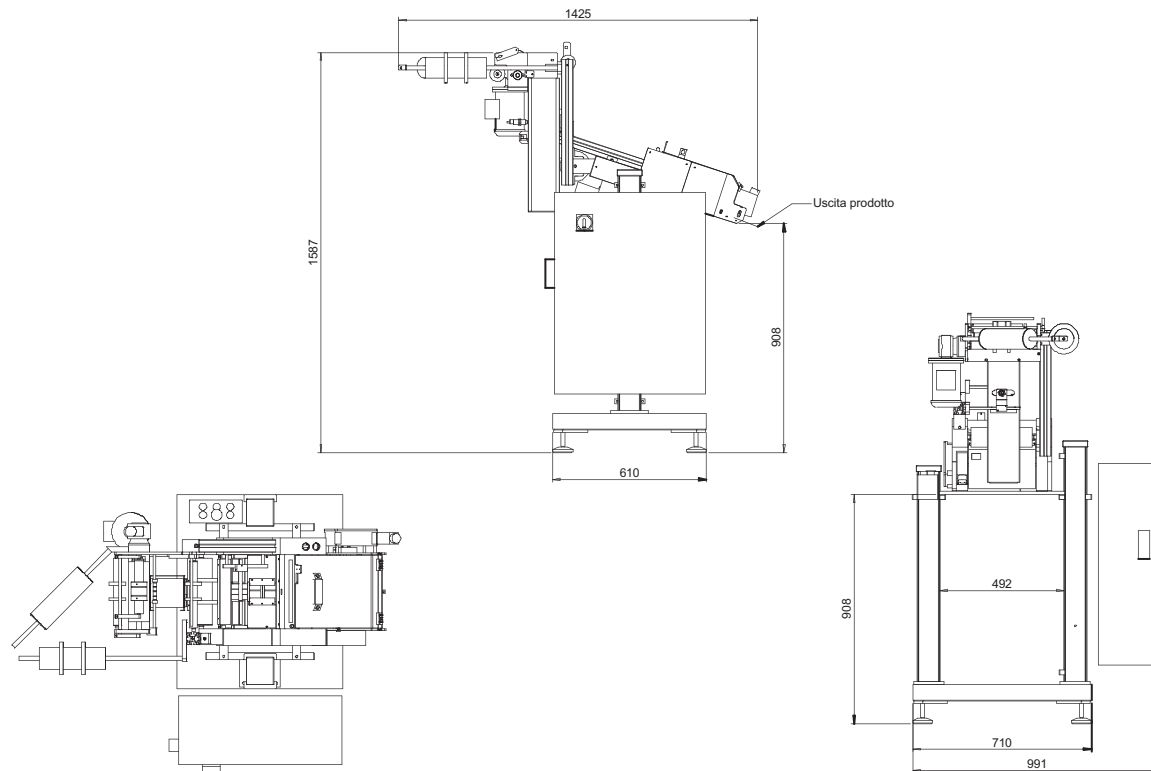

TECHNICAL SPECIFICATIONS

Whizzy Roll

Dispensing speed	130 cpm
Product size length	50 - 150 mm
Product size width	40 - 100 mm
Product thickness	0,5 - 10 mm
Product dispensing	horizontal
Motor	brushless
Machine size length - width - h	700 x 400 x 285 mm
Electrical board size length - width - h	500 x 255 x 700 mm
Power supply	230 V, 50-60 Hz
Electrical input	700 W

Clippy

Pick & place for coupons and gadgets



For coupons and gadgets

Clippy automatically dispenses products thanks to the suction mechanism using a Venturi vacuum generator: coupons and objects are sucked and inserted as products advance. It is available in the pneumatic version or with brushless motor, with a single or double stacker to dispense two different types of objects. The keypad makes it simple to set the speed and control functions:

Etipack reserves the right to modify according to the technical evolution, without notice. All the rights of intellectual and technological ownership are reserved

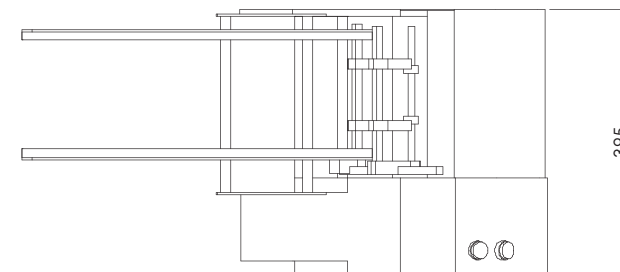
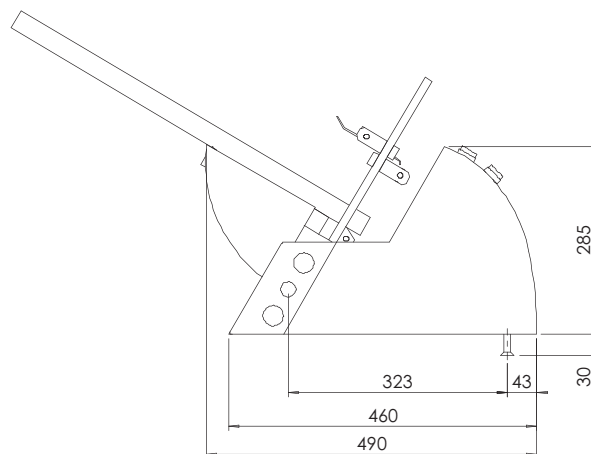

TECHNICAL SPECIFICATIONS

	Clippy PN 0	Clippy BR 0	Clippy BR BIG 0 *
Dispensing speed	50 pcs/min	120 pcs/min	100 pcs/min
Product size length	50 - 200 mm	50 - 200 mm	50 - 200 mm
Product size width	50 - 200 mm	50 - 200 mm	50 - 200 mm
Motor	Pneumatic version	brushless	brushless
Machine size length - width - h	580 x 400 x 400 mm	580 x 400 x 400 mm	1800 x 600 x 1200 mm
Electrical board size	300 x 155 x 400 mm	400 x 200 x 600 mm	–
Power supply	230 V, 50 - 60 Hz	230 V, 50 - 60 Hz	230 V, 50 - 60 Hz
Electrical input	350 W	400 W	1000 W

*with high-level loading stacker 1500 mm length



Clippy OEM

Pick & place for coupons and gadgets

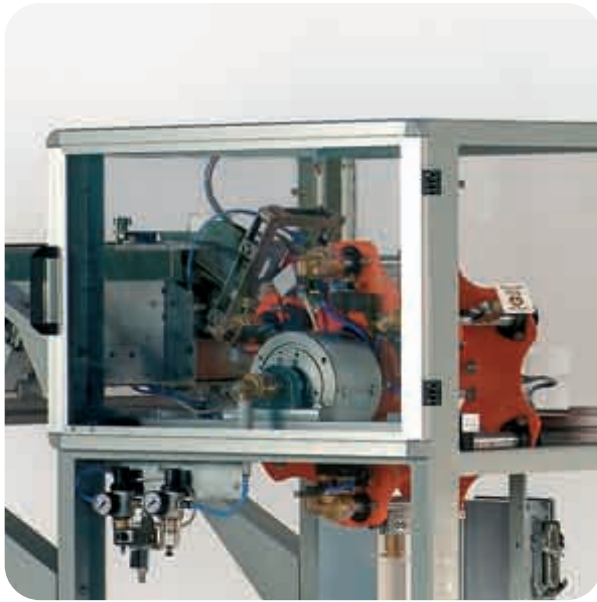

For coupons and gadgets

This rotary pick & place device can be mechanically connected in phase with packaging machines or fitted with its own motor. It dispenses products such as coupons and badges with an output speed of 400 pieces/minute. The products are picked from the stacker by suction pads.

Etipack reserves the right to modify according to the technical evolution, without notice. All the rights of intellectual and technological ownership are reserved

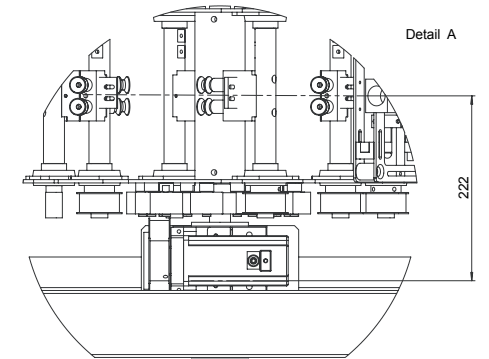
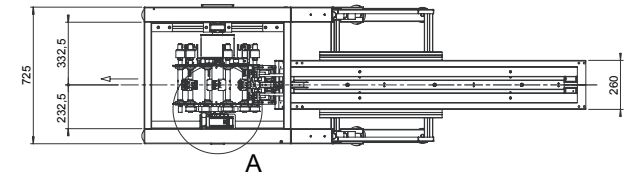
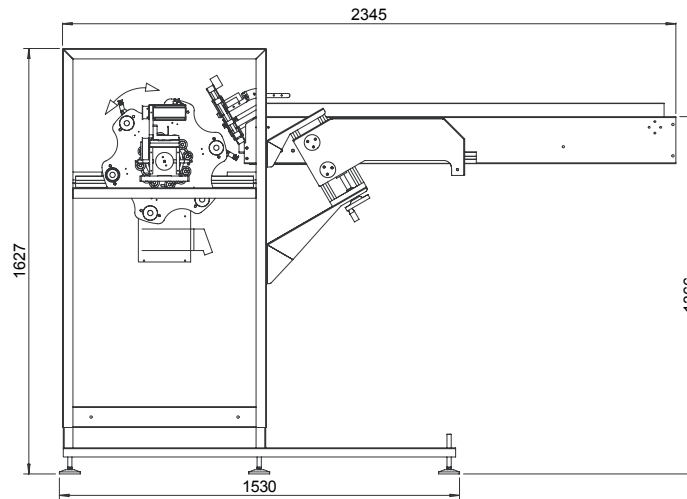

TECHNICAL SPECIFICATIONS

	Clippy OEM
Dispensing speed	400 pcs/min
Product size length	30 - 150 mm
Product size width	30 - 100 mm
Motor	brushless *
Machine size length - width - h	690 x 420 x 440 mm
Electrical board size	—
Power supply	230 V, 50-60 Hz
Electrical input	800 W

* If equipped with its own motor

